

# Crucibles and their Furnaces

# Crucibles

- A crucible is a container that can withstand the very high temperatures necessary to melt glass, metal, pigments and some laboratory materials.
- Bronze and Iron age crucibles were shallow clay vessels and the air for the heat was blown from above. They often had small handles to aid in transport from the furnace to the mold
- In Roman times, due to advances in furnace technology (furnaces switched to heat from below), the crucibles changed to rounded or pointed bottomed conical vessels. They also began using cementation (the process of mixing copper with zinc oxide or carbonate – the zinc vaporizes and binds with the copper to make brass).



Iron Age crucible from  
Llwyn Bryn-dinas hillfort,  
Llangedwyn, Wales, UK

# Crucibles

- In the Mid-evil period, crucibles developed a flat bottom and thinner walls. They also became larger.
- The Roman cementation process was lost until the late middle ages and continued up through the 19<sup>th</sup> century when another cementation process was discovered: steel (although steel through cementation process was performed in India around 300 BC and is commonly known as Damascus Steel – but more on that later)
- In the post Mid-evil period two new type of crucibles were introduced. The Hessen crucible was by far the most successful and made of a high alumina Kaolin clay which was thrown on the wheel and fired in a kiln. This type of clay was not formally “discovered” until the 20<sup>th</sup> century when mullite which is crystallised from the decomposition of aluminium-rich kaolinite clay at temperatures over 1100°C. This material is found in airplane engines and other high temperature locations
- The second type of crucible also came from Germany and was made primarily of graphite. We still use similar crucibles in foundries today.



Hessen Crucibles

# Modern Crucibles

- Crucibles are numbered according to the amount of aluminum they will hold. A number six crucible is about 6.5" tall and 5.25" in diameter. It will hold 6 pounds of aluminum or 18 pounds of bronze/brass.
- For small amounts of low temperature metals you actually can use a heavy steel or cast container (1/4" thick walls).
- Ceramic crucibles are less expensive but not very durable. You do not want to use a large ceramic crucibles, for this reason.



# Crucibles

- Graphite crucibles are relatively inexpensive and used by many foundries in sizes up to 60. However they are fragile and do not have very long lives. (top image)
- Silicon carbide crucibles are the most durable and long lasting. They will handle the most abuse and what I recommend. They are the most expensive of the crucibles, but will last for many years with care. (bottom)



# Care for your crucibles

- Crucibles must always be annealed on 1st use.
- They occasionally need to be re-annealed, by returning to the furnace empty and taking it up to 2000 degrees, then allowing to cool slowly.
- They should never be over packed with cold metal (metal expands when melting).
- They should be heated slowly until the furnace gains color.
- They should be cleaned at the end of the melt.
- They should always cool in a warm furnace and never allowed to cool in ambient temperatures.
- Store your crucibles on wood blocks or upside-down. Do not store them in places where they will get wet or freeze.
- The sides and lips should be dressed regularly.
- Always examine your crucible carefully before each melt. The “ring” test should help you find cracks.
- **NEVER EVER USE A CRUCIBLE THAT LOOKS LIKE THESE! METAL CASTING IS DANGEROUS! AND THE PRICE OF A NEW CRUCIBLE IS LESS THAN THE PRICE OF A TRIP TO THE ER!!!**



# Crucible Tools: Shank

- The shank holds the crucible for pouring molten metal.
- They should be adjustable, as even the same size crucibles can vary. In this example there are three pieces of angled steel which adjust forward and back on a bolt via two nuts.
- The handles should be the width of your arms hanging straight at your sides.
- It should have a solid clamping system to hold the crucible in place while pouring (you do not want it to fall out when it is full!)
- The ring of the shank should fit just below the hip or widest point of the crucible. This will keep the crucible from falling through when carrying and is at the right balance/pivot point to make pouring metal the least difficult.





## Crucible Tongs

Tongs should allow you to lift the crucible easily from the furnace. They should also cradle the crucible gently, it should not rock back and forth, it should not pinch the crucible.



# Other tools you will need

- Skimmer
- Ingot tongs
- Ingot molds

You may also need:

- Mold weights
- Flasks
- Mold tongs

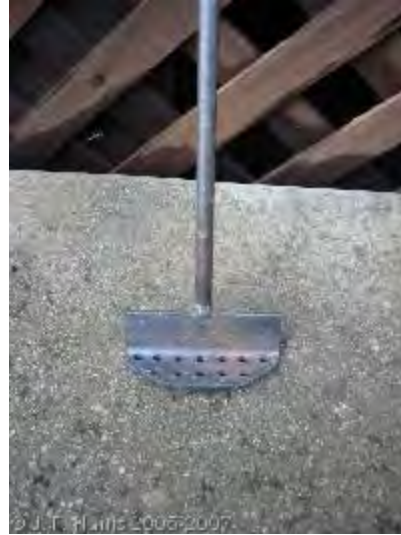

# Crucible furnace design basics

- Round furnaces are more efficient than square furnaces.
- Furnaces should be sized according to the number crucible you are using.
- They should be 6-12" wider than the diameter of your crucible.
- The furnace height, with liner, should account for a crucible block which gets the crucible above the force of the flame and allow 1-2" of space between the lip of the crucible and the lid.
- The burner port or tueyer (tweer) should be placed below the bottom of the crucible and be tangent to the side of the furnace liner.
- Depending on the metal you are melting and the liner you are using, allow for a liner thickness of 3-6"

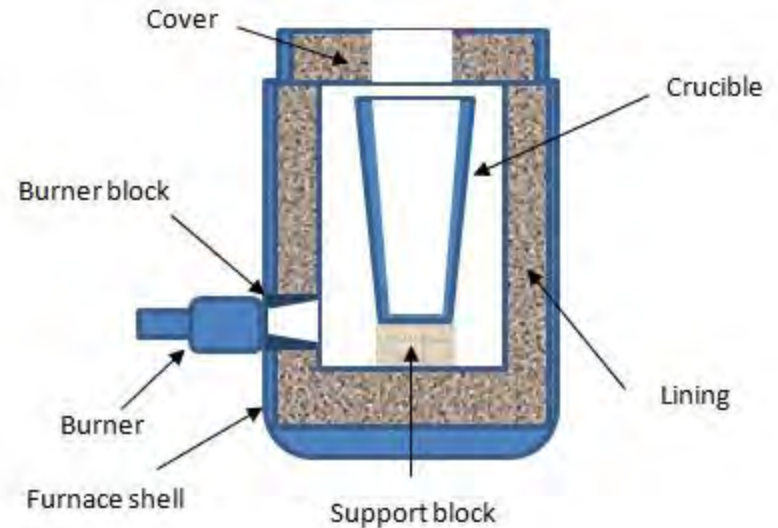

# Liner for the furnace

- The best liners are pre-cast bricks made of alumina ceramic or silicon carbide. If you buy a furnace, it will usually have this type of liner.
- Otherwise you will cast or ram your liner which will be made from a high temperature refractory – usually a clay or cement.
- There are a great number of refractories on the market. Be sure the material you are using will work for the temperatures and metals you are using.
- The choice between castable or ramable is a highly personal one. I prefer ramable for the control, although castable produce nicer surfaces and are faster to form
- My favorite is a product called “Meltzona” that comes from Alabama, it is inexpensive, withstands the temperatures of iron and fluxes over instead of fluxing out.
- After you have cast or rammed your liner, you want to let it sit overnight tightly wrapped in plastic and then fire it in slowly the next day.
- It is very important not to let surface of the refractory dry out or it may skin over and trap moisture inside. When this liner is fired it is very likely to crack.

# Charcoal Crucible Furnace

- Charcoal fired crucible furnaces have been used for thousands of years and run on similar principles as modern furnaces.
- Essentially you have a crucible which is surrounded by fuel (charcoal, coal or coke) and accelerated by the addition of forced air.
- Two of the biggest changes in technology were making the furnace cylindrical and having the forced air come in the from the bottom.

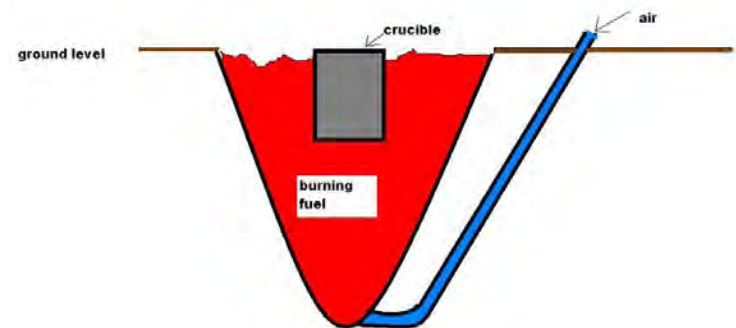

# Running a Charcoal furnace

- Charcoal fired furnaces are one of the easiest furnaces to build and run on a small scale (under 150 pounds of bronze).
- Essentially you have a refractory lined cylinder which has a hole place perpendicular and near the bottom.
- A low powered blower is inserted into the blower port or tueyer (tweyer).
- Then approximately 4" of charcoal is placed in the bottom and lit.
- The crucible is placed on top of the warm coals and charged loosely with metal.
- Charcoal is then placed around the crucible up to the top lip. In some instances the crucible is actually covered with the charcoal (such as in melting copper).
- The lid is then placed over the furnace and the blower turned on
- In adjusting the blower, you are looking for a neutral or slightly reducing flame. If there is smoke, you are reducing. If it is too oxidizing you are chancing oxidizing your metal and also may be burning too high. Adjust the blower to the point that it no longer visible effects the flame and then turn it down or shutter it slightly.
- You may need to readjust the flame as the furnace gets going.
- You may need to remove the lid and crucible during long melts and add more fuel.

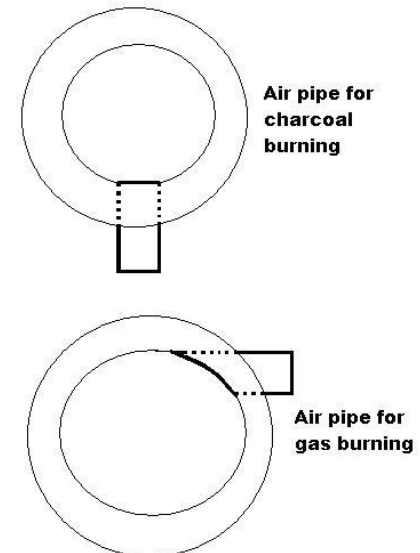

# Oil-fired Furnace

- An oil-fired furnace is basically a cylindrical furnace that uses any oil based substance from wax to motor oil as a fuel.
- The burner is designed so that the oil drips into the burner tube and ignites.
- They are very fast furnaces that are inexpensive to operate.
- There is some smoke involved and the burners can be fussy – they lack the ease of gas furnaces.



Oil drip furnace built by Colin Peck out of a beer keg. This particular furnace runs on both waste engine oil as well as the more environmentally friendly, kitchen fryer oil. The furnace will hold around a #9 crucible and will get hot enough to melt iron – as you can see he has cast his own crucibles out of iron from flower pots below.



# Various Oil Fired Furnaces



Kansas Brass Oil Fired Furnace



# Oil burner design

There are a wide variety of designs for oil drip burners, but the basic principles remain the same. Drip oil (pressurized or gravity fed) into a burn chamber, where it is ignited and the resulting flames pushed out through a burner tube. Some designs are fairly simple like the one below and others incredibly complex pressurized systems with filters for the oil.



Colin Pecks paraffin burner which uses a dryer motor and cookie tin in the construction.

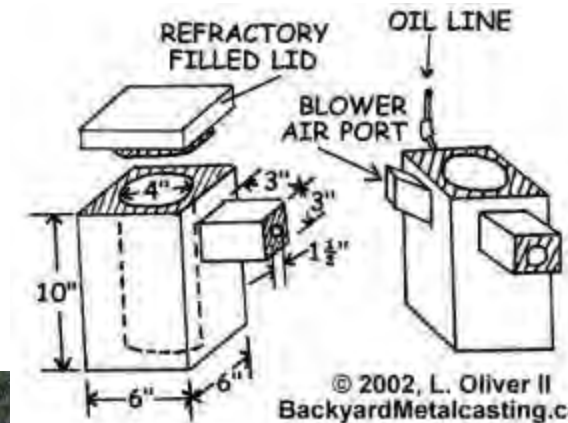
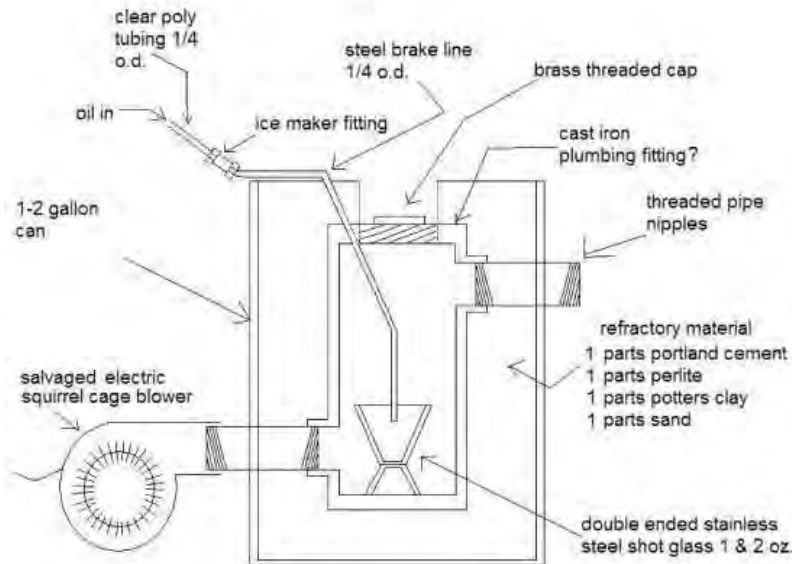

Copyright 2002, L. Oliver II - BackyardMetalcasting.com



# Advantages and Disadvantages of oil

- Oil is readily available and easily stored.
- Although burning oil does produce carbon, the source of oil is often recycling – either motor oil or cooking oil. (Note: used oil must be strained before use and *used motor oil can contain toxins such as lead.*)
- If the burner goes out the oil will pool in the burner – although this is less dangerous than gas which can fill a room and ignite.
- It takes a larger burner to burn oil, it is harder to light and takes a few minutes to heat up.
- Oil burners do not need any equipment like gauges that cannot be easily be built.



# Oil-fired furnace



Oil fired furnaces can be run “cupola” style, without a crucible - the metal is tapped out of the bottom. In this case, Colin Peck is melting copper. If diesel is used for fuel, you can actually melt iron.



Running the flame in slight reduction is still important. This furnace is being run “rich” – it has too much fuel in the mixture.

# Gas Crucible Furnaces

- Professional gas fired crucible furnaces, such as this one by MIFCO, will have an cast brick liner, an electric start, a UV scanner (which assists in starting and also will automatically shut the furnace down if it senses a fluxation in the flame).



There is a wide variation in furnace design, but as long as you stick to these basic principles, you should have a working furnace

- Round furnaces are more efficient than square furnaces.
- Furnaces should be sized according to the number crucible you are using.
- They should be 4-6" wider than the diameter of your crucible.
- The furnace height, with liner, should account for a crucible block which gets the crucible above the force of the flame and allow 1-2" of space between the lip of the crucible and the lid.
- The burner port or tueyer (tweer) should be placed below the bottom of the crucible and be tangent to the side of the furnace liner.
- Depending on the metal you are melting and the liner you are using, allow for a liner thickness of 3-6"

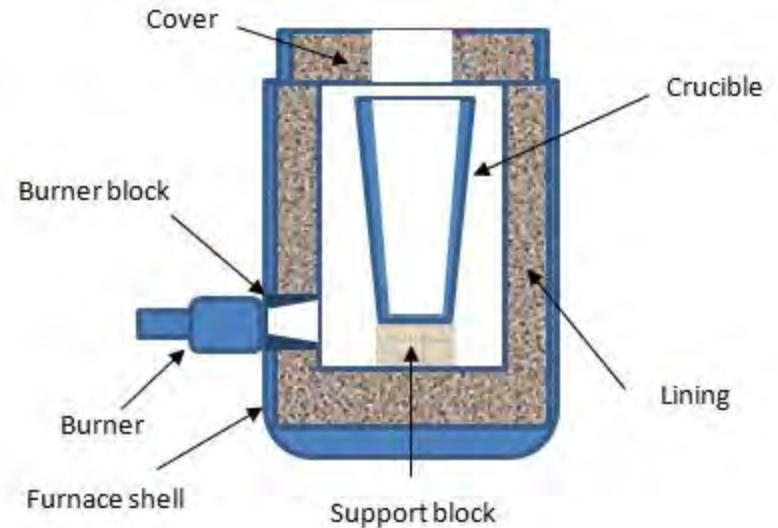

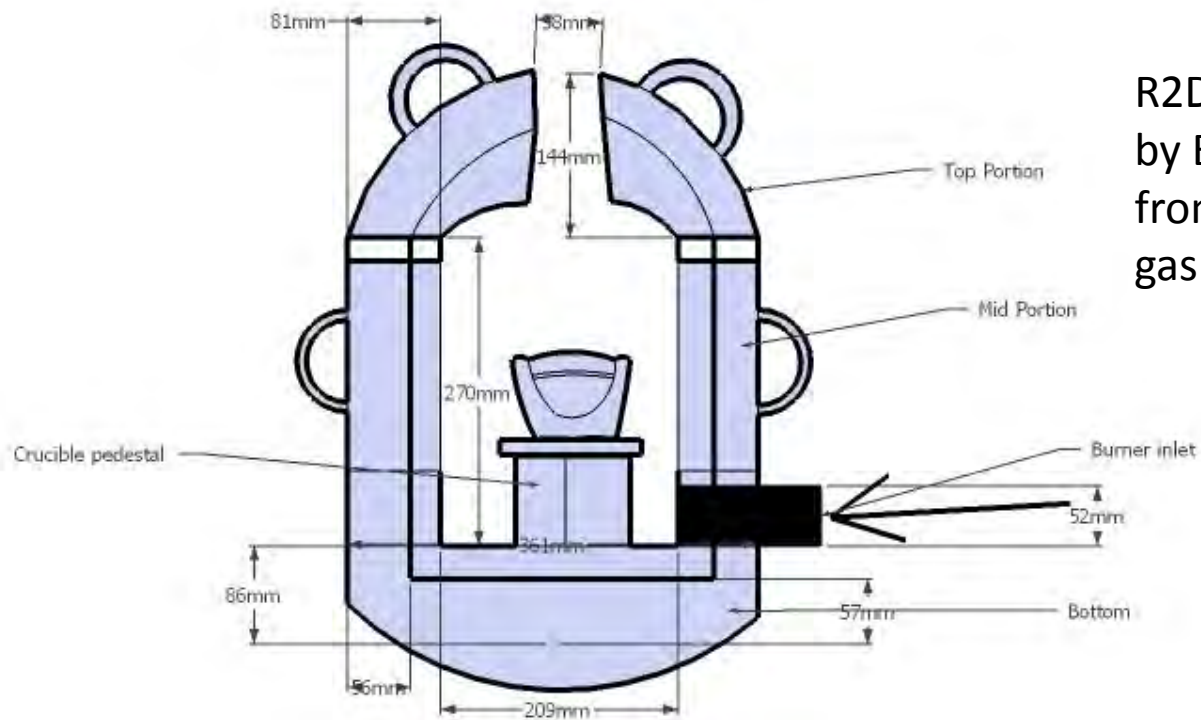

R2D2 looking furnace built by Emre, a knifemaker from Turkey out of a LP gas tank.





Simple furnace that holds a #30 crucible. It actually has a pair of tangentially oriented burner holes, but only one is really necessary



# Lionel Oliver's coffee can and dirt and brick furnaces





David Speers freon tank furnace

Ideas are really only limited by  
your imagination



Gene Elliot's coffee can furnace



Cowboy furnace by Lost &  
Foundry Co. in Spokane, WA



# Burner Design

- There are also a wide variety of burner designs
- First you need to determine whether you are using natural gas or propane (or another fuel gas). BURNER DESIGNS ARE DIFFERENT FOR EACH FUEL!
- You also need to decide whether or not you are going to use a blower or rely purely on a venturi system. Generally if your furnace uses over a #10 crucible or will be melting copper based metals, you will need a blower.



Propane venturi burners by [Hybridburners.com](http://Hybridburners.com)

Ron Reil's burner designs are very popular among home builders looking for a venturi design.

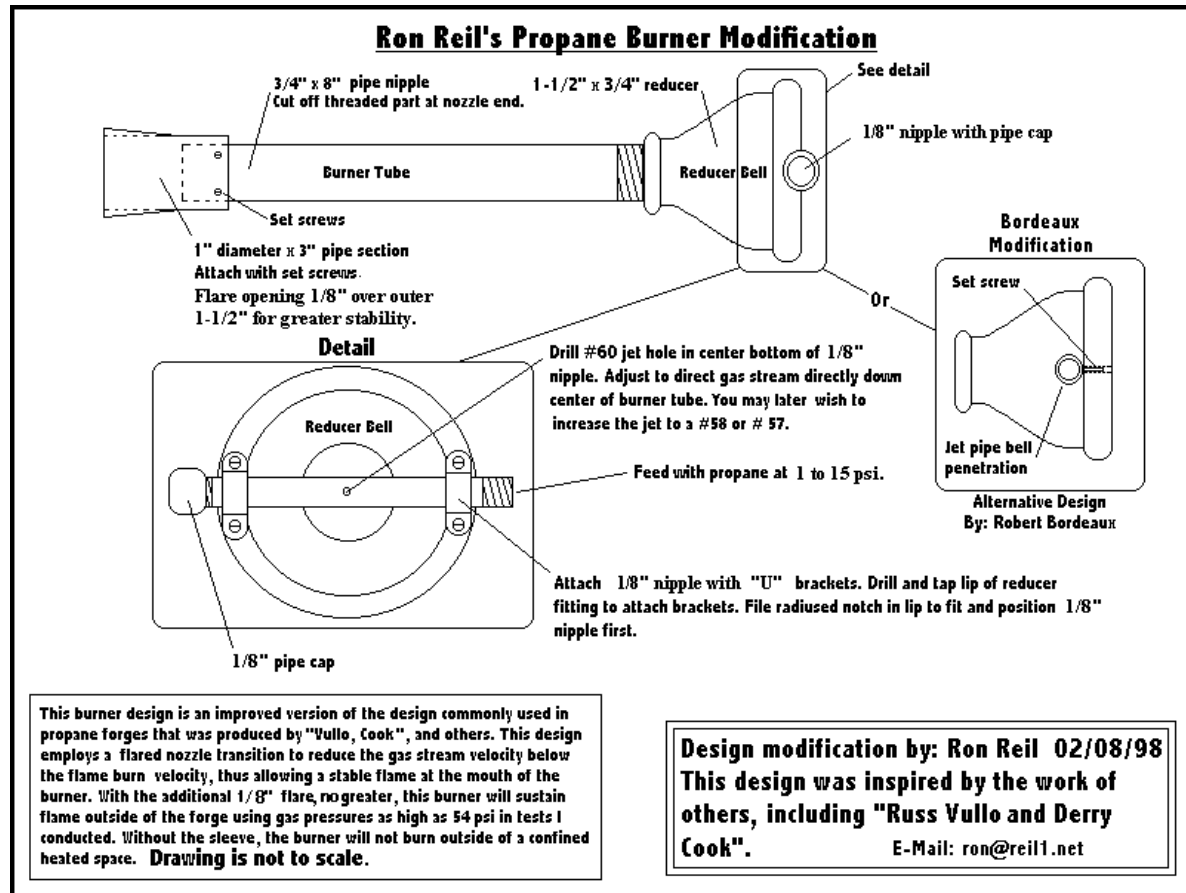

Propane (LP) burners will always have a small interior hole that propels gas into the burner tube surrounded by a series of exterior holes which allow the air to mix into the gas (mixing chamber).

# Reduction through oxidizing on a Venturi Burner

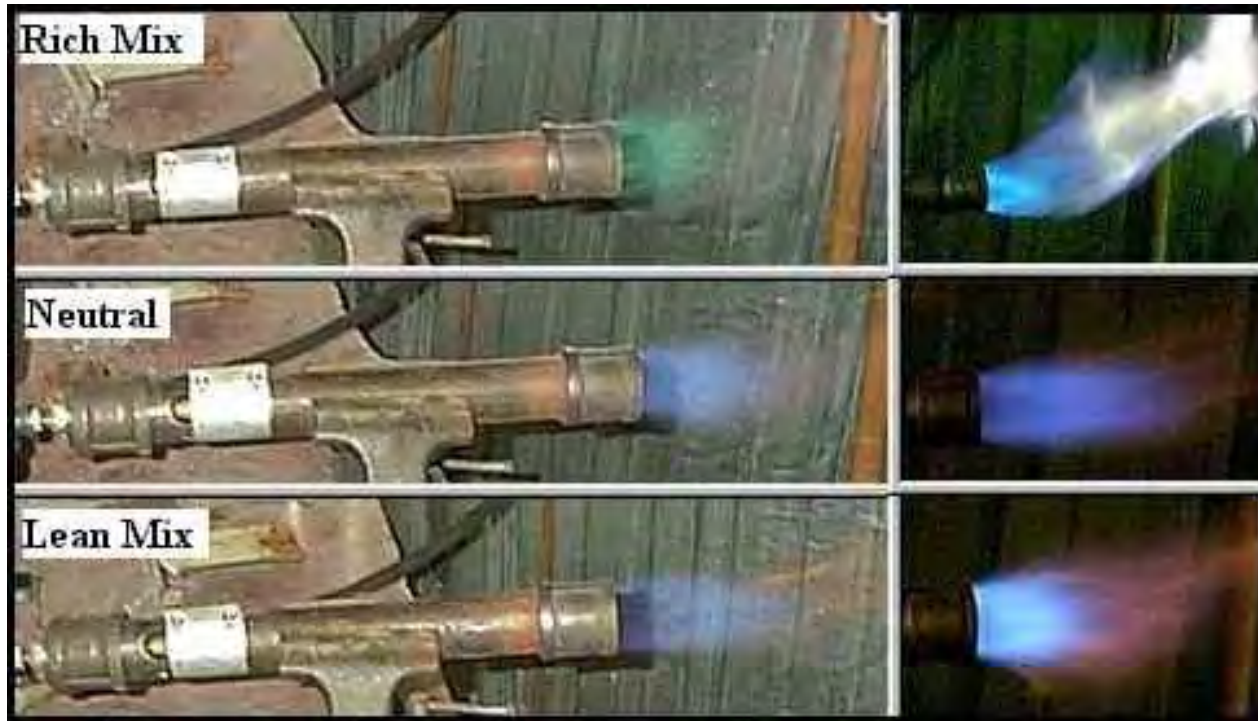
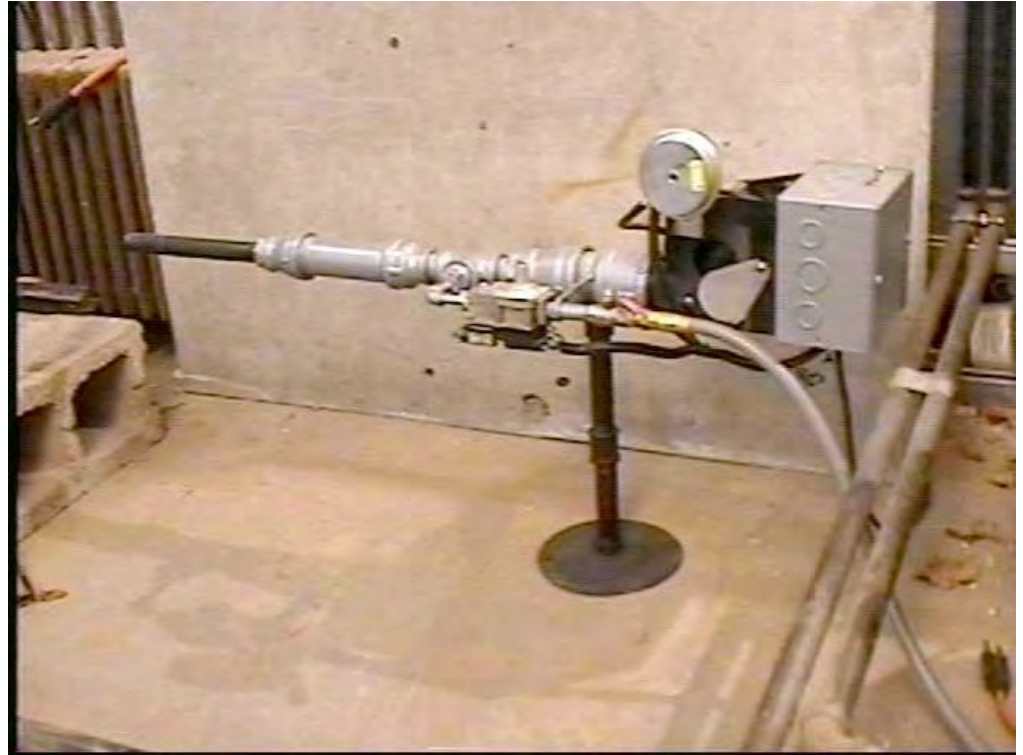

Image from Ron Reil at <http://ronreil.abana.org>

# Natural Gas Burners

- Natural Gas systems should have some added safety features: a vacuum switch which will turn off gas if the flame goes out and a UV scanner or heat probe to sense the presence of flame.
- An easily reached emergency shut off valve (or two) are also recommended.



# Yet to come: design for the burner I use

*Any one who wants to measure and draw out my burner and create a Solidworks or Rhino drawing will get 25 points of extra credit*

# Safety Warnings about burners

- Do not allow the flame to burn back inside the tube – this can have dangerous results.
- This is usually caused either by an improper mix ratio or a faulty design.
- If you cannot get it to run without burning inside of the tube, you need to reconsider your design. Frequently this is do to problems with your air/gas mixture chamber.
- Also you should consider a flash back arrestor on your line.
- If you are running on natural gas it is also recommended that you have a flame sensor of some type hooked up to a vacuum switch.



# Electric Resistance Crucible Furnace

- Basically electricity is run through coiled wire that is slightly too small for the amount of current that is being forced through it. This resistance causes heat as a by product.
- Advantages: environmentally sound, produces only waste gas from the metal itself.
- Disadvantages: melts slowly, most have a round a 2050 top temperature, cannot melt in reduction, melts only smaller amounts.
- All of the dangers that come with electricity, plus additional ones if your crucible cracks inside the furnace.



# Homebuilt Electric Resistance Furnace

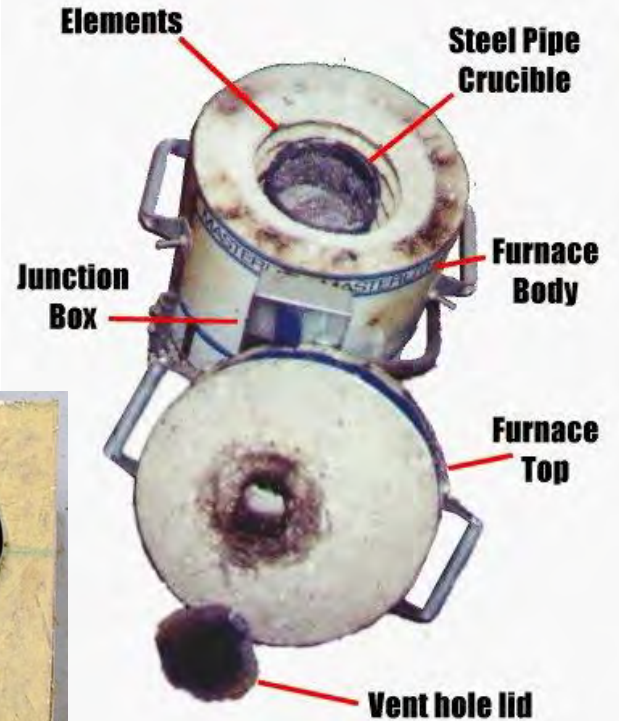

Dave Gingery has plans that can be found for building a furnace of this nature and a few people offer suggestions for improvement, such as this guy: <http://www.dansworkshop.com>



